

World Class Design | World Class Function | 30 Years Expertise in Industrial Motor Control

DC MOTOR DRIVE

1600i / 3200i

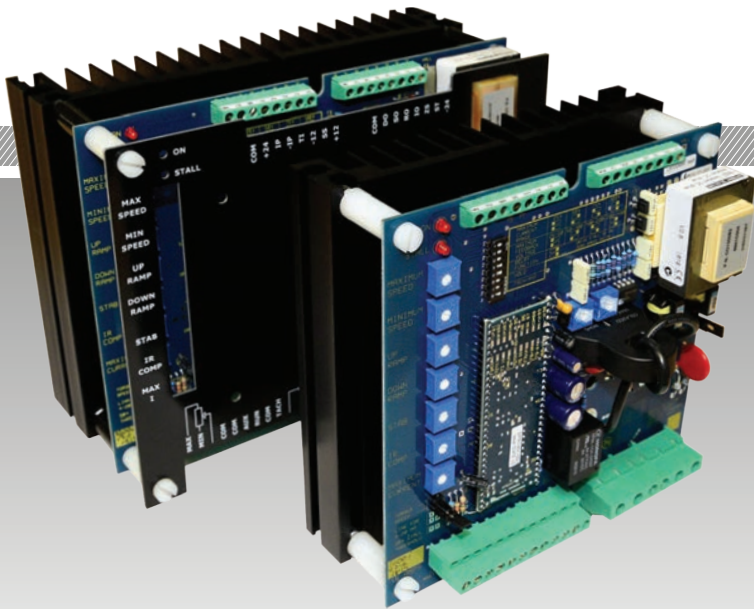

SPRINT ELECTRIC

Please read this information before installing or using the product.

Install, use and maintain this product following the procedures provided.

The manual(s) cannot provide all details, variations and contingencies required for your installation, operation and maintenance of this product or the apparatus with this product installed. For further help or information, refer to your local Supplier sales office.

Application area

The equipment described is intended for industrial (non-consumer) motor speed control.

Intended users

To safely enable the user to obtain maximum benefit from the equipment:

- Ensure this information is available to all persons required to install, configure or service the described equipment or any other associated operation.
- Always store the manual in a conveniently accessible area for quick reference.
- Make it available for the next user/owner of the product.

This product is of the restricted sales distribution class according to IEC 61800-3 and has a "professional equipment" designation as defined in EN 61000-3-2.

Safety

Ensure all users and operators understand the included WARNINGS, CAUTIONS and NOTES, which alert the user to safety issues. COMPLY WITH WARNINGS AND CAUTIONS AT ALL TIMES. Each of these carries a special meaning and should be read carefully:



WARNING!

A WARNING is given when non-compliance with the warning may result in personal injury and/or equipment damage.





CAUTION!

A CAUTION is given when non-compliance with the caution may result in permanent equipment damage.

NOTE A note provides specific information to make important instructions clear.

Symbols

 Attention	 Electrostatic Discharge (ESD)	 Electric Shock Hazard
See the instructions for use. Specific warnings not found on the label.	This equipment contains ESD sensitive parts. Observe static control precautions when handling, installing and servicing this product.	Disconnect the mains supply before working on the unit. Do not touch presets, switches and jumpers! Always use the correct insulated adjustment tools.



WARNING!

Only qualified personnel must install, operate and maintain this equipment.

A qualified person is someone technically competent and familiar with all safety information, established safety practices, installation, operation, maintenance and the hazards involved with this equipment and any associated machinery.

Hazards

This equipment can endanger life through rotating machinery and high voltages.



WARNING!

PERSONAL INJURY AND/OR ELECTRICAL SHOCK HAZARD

- Always isolate all power supplies from the equipment before starting any work.
- Never perform high voltage resistance checks on the wiring without first disconnecting the product from the circuit under test.
- Use guarding and additional safety systems to prevent injury and electric shock.
- Metal parts may reach 90°C during operation.



CAUTION!

EQUIPMENT DAMAGE HAZARD

- We thoroughly test our products. However, before installation and start-up, inspect all equipment for transit damage, loose parts, packing materials, etc.
- Installation must observe the required environmental conditions for safe and reliable operation.
- In a domestic environment, this product may cause radio interference, requiring adequate measures to be taken. Obtain the permission of the supply authority before connecting to the low voltage supply.

General risks

Installation

- Ensure mechanically secure fixings are in use as recommended.
- Ensure cooling airflow around the product is as recommended.
- Ensure cables/wire terminations are as recommended and are torqued correctly.
- Ensure the product rating is correct - do not exceed the rating.

Application risk

Electromechanical safety is the responsibility of the user. The integration of this product into other apparatus or systems is not the manufacturer's or distributor of the product's responsibility. It is the user's responsibility to ensure the compliance of the installation with any regulations in force.

Health and safety at work

Electrical devices can constitute a safety hazard. Thorough personnel training is an aid to SAFETY and productivity. SAFETY awareness not only reduces the risk of accidents and injuries in your plant but also has a direct impact on improving product quality and costs. If you have any doubts about the SAFETY of your system or process, consult an expert immediately. Do not proceed without doing so. If in doubt, refer to the Supplier.

Weight

Consideration should be given to the weight of our heavier products when handling.

Risk assessment

Under fault conditions or conditions not intended: the motor speed may be incorrect; the motor speed may be excessive; the direction of rotation may be incorrect; the motor may be energised.

In all situations, the user should provide sufficient guarding and/or additional redundant monitoring and safety systems to prevent risk of injury.

NOTE: During a power loss event, the product will commence a sequenced shut-down procedure. Therefore, the system designer must provide suitable protection for this case.

Maintenance

Only qualified personnel should maintain and effect repair using only the recommended spares, alternatively return the equipment to the factory for repair. The use of unapproved parts may create a hazard and risk of injury.



WARNING!

PERSONAL INJURY AND/OR EQUIPMENT DAMAGE HAZARD

When replacing a product, all user-defined parameters that define the product's operation must be installed correctly before returning to use. Failure to do so may create a hazard and risk of injury.

The packaging is inflammable and incorrect disposal may lead to the generation of lethal toxic fumes.

Repairs

Repair reports can only be given if the user makes sufficient and accurate defect reporting. Remember that the product without the required precautions can represent an electrical hazard and risk of injury, and that rotating machinery is a mechanical hazard.

Protective insulation

Isolated product



WARNING!

The drive and motor must be connected to an appropriate safety earth. Failure to do so presents an electrical shock hazard. Exposed metal work in this equipment is protected by basic insulation and bonding to a safety earth.

This product is classified as a component and must be used in a suitable enclosure.

1. This is achieved through basic insulation and protective earth grounding, or double-insulation to provide SELV Control Circuits.
2. This protection allows a safe connection to other low voltage equipment.
3. **Earth bonding is the responsibility of the installer.**

Contents

1 Introduction	1
2 Installation	2
2.1 Motor installation.....	2
2.2 Drive Installation.....	2
2.3 Guide for systems used in the EU	4
2.4 Multiple drives.....	4
2.5 Requirements for EMC compliance	5
2.6 Typical applications.....	6
2.7 Block diagram and terminal specifications.....	8
3 Commissioning	11
3.1 Initial settings - without power.....	11
3.2 Pre-operation motor check list.....	12
3.3 Operating the drive	12
4 Options	14
5 Trouble shooting	15
6 Specifications	16

1 Introduction

APPLICATION AREA: Industrial (non-consumer) "Motor speed control utilising DC Motors".

DRIVE MODEL	AC SUPPLY VOLTAGE	AMERICAN OPTIONS	NOMINAL OUTPUT VOLTAGE	MAXIMUM CURRENT	PRODUCT DISSIPATION at full current	ISOLATION
1600i/LV	60/30		48/24	16 A	50 W	isolated
1600i	240/110		180/90	16 A	50 W	isolated
3200i/LV	60/30		48/24	8/16/32/48 A	25/50/100/150 W	isolated
3200i	415/240	240/110	320/180/90 *	8/16/32/48 A	25/50/100/150 W	isolated

* USA

The 1600i and 3200i have identical functionality, however the 1600i is designed for operation Line-to-Neutral (240 V nominal) and the 3200i for operation Line-to-Line (415 V nominal).

- All models are of open chassis construction for use in a suitable enclosure.
- The drives have isolated control electronics.
- Closed loop control of both armature current and feedback voltage for precise control of motor torque and speed.
- Motor and drive are protected by a stall timer to automatically remove power after 30 seconds if the required speed cannot be achieved.
- Up to 150% of the preset maximum current for up to 30 seconds allowing for high, short-term torques during acceleration etc.
- Independent control of either the current or speed loops by external inputs allow for torque or speed control applications with overspeed or overcurrent protection.
- Demand signal can be derived from a potentiometer, 0-10 V signal or 4-20 mA loop.
- Speed feed back signal selection: ARMATURE VOLTAGE, or shaft-mounted TACHOMETER.

Input and outputs	+aux input	speed output	+24 V unregulated output
	-aux input	current output	+12 V regulated output
	current input	ramp output	+10 V precision reference
	4-20 mA input	demand output	-12 V regulated output
	0 to 10 V input	zero/stall relay	-24 V unregulated output
Adjustable parameters	Max speed	Up ramp	Max current
	Min speed	Down ramp	IR comp
			Stability
Switched functions	Max current range	Max feedback	Tacho feedback
	Relay function	Power up hold	AV feedback
Jumper functions	Torque mode	Dual supply voltage	Phase angle limit
	Zero reference interlock	4-20 mA input	50% stall threshold
Performance features	Dual loop control	Precision tacho rectifier	Compact design
	Relay driver outputs	International compatibility	System inputs/ outputs

2 Installation



WARNING!

ELECTRIC SHOCK HAZARD

Disconnect the mains supply before working on the unit. **DO NOT TOUCH PRESETS, SWITCHES AND JUMPERS!** Always use the correct insulated adjustment tools.

2.1 Motor installation

- Foot-mounted motors must be level and secure.
- Ensure accurate alignment of the motor shaft and couplings.
- Do not hammer pulleys or couplings onto the motor shaft.
- Protect the motor from ingress of foreign matter during installation.

Earthing: Connect the motor to the system enclosure earth.

2.2 Drive Installation

Requirements during installation and operation:

- Optimise the heatsink airflow.
- Avoid vibration.
- Protect the drive from pollutants.
- Ambient operating temperature must be within -10°C and +40°C. To comply with UL requirements, the temperature of the surrounding air must not exceed 50°C.

POWER CABLING: Use correctly rated cable: minimum 600 Vac, 2 x armature current

CONTROL SIGNALS: The 1600i and 3200i have isolated control terminals and as such may be connected to other systems. Avoid running signal cables close to power cables.

SUPPLY: Please ensure that the supply selection jumper on the drive matches the incoming supply. Failure to do this may result in permanent damage to the drive unit and will invalidate any warranty.

FUSING: The drive **MUST BE FUSED EXTERNALLY** with semiconductor fuses that **MUST** be rated at 1.75 x armature current, and have an A²s rating lower than the I²t value listed on page 16. **Any warranty will be invalid if this fusing is incorrect.**

1600i/3200i	Fuse	Holder	Clearing I ² t
8 A	CH00620A	CP102071	259 A ² s
16 A	CH00730A	CP102053	259 A ² s
32 A	CH00850A	CP102054	770 A ² s
48 A	CH00880A	CP102054	2550 A ² s

SUPPRESSION: The drives have excellent noise immunity. However, installations involving electrical welding or RF induction heating may require further filters on the line and armature terminals. Contactor coils and sparking contacts may also require suppression. A 100 Ω resistor in series with a 0.1 μF capacitor is usually adequate in these situations. Refer to page 5 for EMC guidelines.



CAUTION!

EQUIPMENT DAMAGE HAZARD

Reversing systems: do not transpose the armature connections until the motor has stopped, otherwise damage will occur.



CAUTION!

EQUIPMENT DAMAGE HAZARD

For frequent stopping or jogging, it is not good practice to rely on switching the supply off and on to stop and start with the run contact permanently closed.

This may result in an uncontrolled current pulse for one half mains cycle under certain conditions, e.g. main contact bounce. This could lead to undesired motor movement or device damage.

In rapid start-stop systems, use a spare normally-open contact on the main supply contactor in series with T7 and any other RUN contacts.

2.2.1 Mechanical dimensions

The unit must have a substantial earth. Connect the earth to the heatsink earth screw provided using a star washer to obtain optimum earth continuity.

Fixing bolts:

1600i M5 x 35 mm

3200i M5 x 50 mm

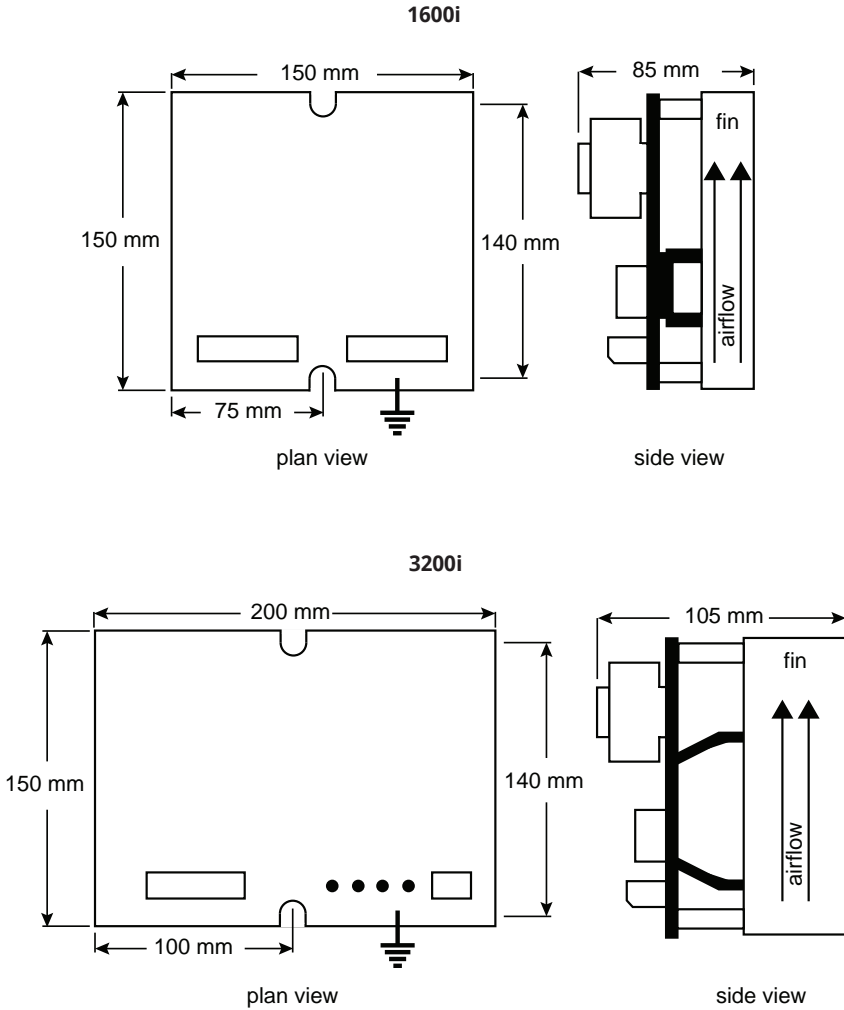

Figure 1 Mechanical dimensions

2.3 Guide for systems used in the EU

Special consideration must be given to installations in member states of the European Union regarding noise suppression and immunity. According to IEC 1800-3 (EN61800-3) the drive units are classified as complex components only for professional assemblers, with no CE marking for EMC.

The drive manufacturer is responsible for the provision of installation guidelines. The resulting EMC behaviour is the responsibility of the manufacturer of the system or installation. The units are subject to the LOW VOLTAGE DIRECTIVE 73/23/EEC and are CE marked accordingly.



Following the procedures outlined below will normally be required for the drive system to comply with the European regulations, some systems may require different measures. Installers must have a level of technical competence to correctly install. Although the drive unit itself is not subject to the EMC directive, considerable development work has been undertaken to ensure that the noise emissions and immunity are optimised.

- * EN618003 specifies two alternative operating environments. These are the Domestic (1st environment) and Industrial (2nd environment). There are no limits specified for conducted or radiated emissions in the industrial environment, hence it is usual for the AC supply filter to be omitted in Industrial systems.

Definition of an industrial environment: all establishments, other than those directly connected to a low-voltage power supply network that supplies buildings used for domestic purposes.

2.4 Multiple drives

The arrangement shown below is for multiple drives with one filter, showing the star point earthing method.

The filter should be rated for the worst case total armature current load. The drive units are designed to function normally on unfiltered AC supplies shared with other thyristor DC drives. (Not AC drives).

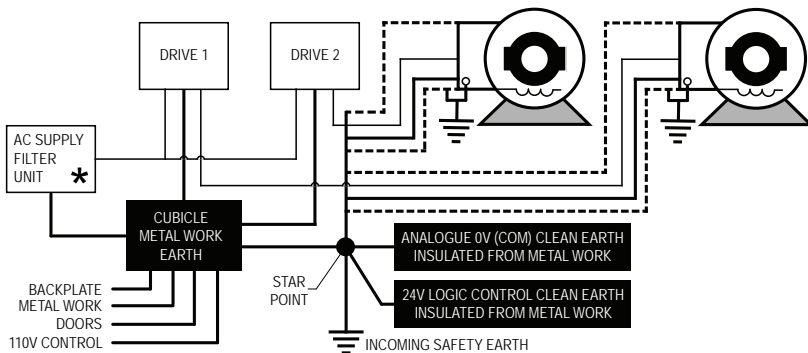

Figure 2 Star point connections for multiple drives

2.5 Requirements for EMC compliance

- Keep parallel runs of power and control cables at least 0.3 metres apart. Cross-overs must be at right angles.
- Keep sensitive components at least 0.3 metres from the drive and power supply cables.
- The AC connections from the filter to the drive must be less than 0.3 metres or, if longer, correctly screened.
- Do not run filtered and unfiltered AC supply cables together.
- Control signals must be filtered or suppressed, e.g. control relay coils and current carrying contacts. The drive module has built-in filters on signal outputs.
- The AC supply filter must have a good earth connection to the enclosure back plane. Take care with painted metal to ensure good conductivity.
- The AC input filter has earth leakage currents. Earth RCD devices may need to be set at 5% of rated current.
- The metal enclosure will be RF ground. The AC filter, drive earth and motor cable screen should connect directly to the metal cabinet for best performance.
- Linear control signal cables must be screened, with the screen earthed at the drive end only. Minimise the length of screen stripped back and connect it to an analogue earth point.
- (1) The motor cable must be screened or armoured with 360 degree screen terminations to earth at each end. The cable must have an internal earth cable and the screen must extend into the enclosure and motor terminal box to form a Faraday cage without gaps.
- (2) The internal earth cable must be earthed at each end. The incoming earth must be effective at RF.
WARNING! The earth safety must always take precedence.



WARNING!
ELECTRIC SHOCK HAZARD

AC supply filters must not be used on supplies that are unbalanced or float with respect to earth.

The drive and AC filter must only be used with a permanent earth connection. No plugs/sockets are allowed in the AC supply.

The AC supply filter contains high voltage capacitors and should not be touched for a period of at least 20 seconds after the removal of the AC supply.

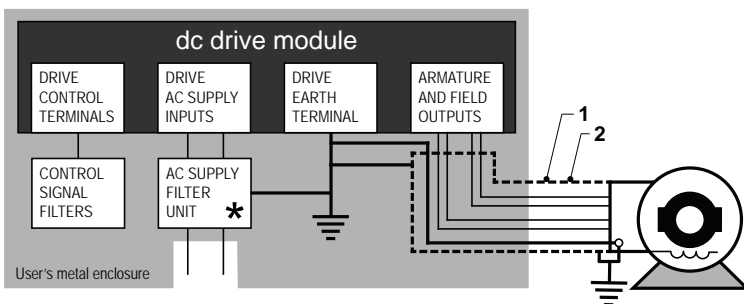

Figure 3 Connections for EMC compliance

2.6 Typical applications

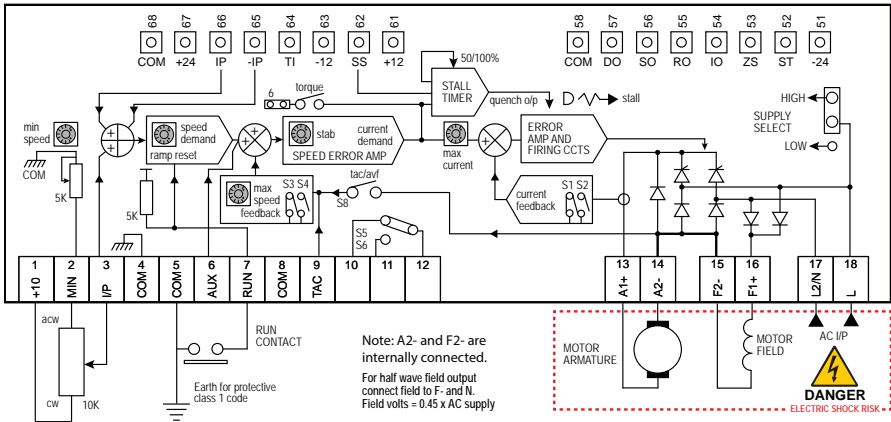

Figure 4 1600i: Basic connection

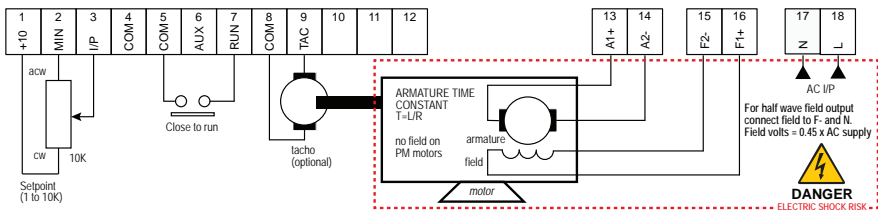

Figure 5 1600i: Basic connection with optional tacho

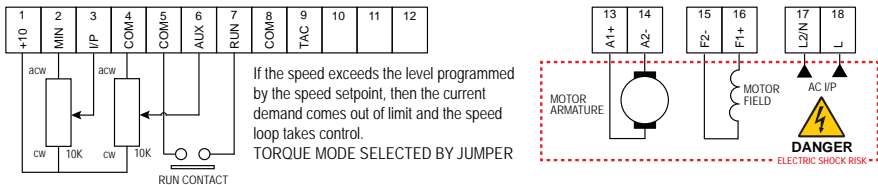

Figure 6 1600i: Torque control with overspeed limiting by separate setpoint

SPRINT ELECTRIC LTD. does not accept any liability whatsoever for the installation, fitness for purpose or application of its products. It is the user's responsibility to ensure that the unit is correctly used and installed.

Health and Safety at Work
Devices constitute a safety hazard. It is the responsibility of the user to ensure compliance with any Acts or By-Laws in force. **ONLY skilled persons should install this equipment.**

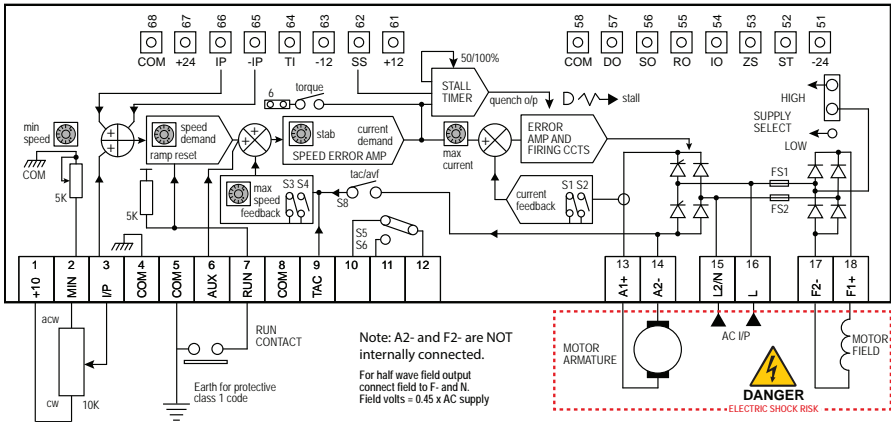

Figure 7 3200i: Basic connection

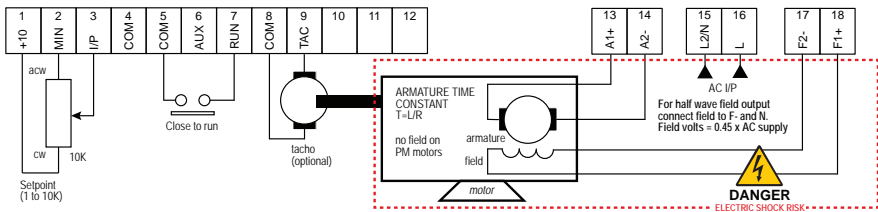

Figure 8 3200i: Basic connection with optional tacho

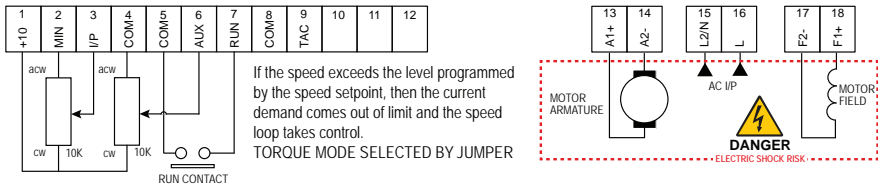

Figure 9 3200i: Torque control with overspeed limiting by separate setpoint

SPRINT ELECTRIC LTD. does not accept any liability whatsoever for the installation, fitness for purpose or application of its products. It is the user's responsibility to ensure that the unit is correctly used and installed.

Health and Safety at Work
Devices constitute a safety hazard. It is the responsibility of the user to ensure compliance with any Acts or By-Laws in force. **ONLY skilled persons should install this equipment.**

2.7 Block diagram and terminal specifications

1600i

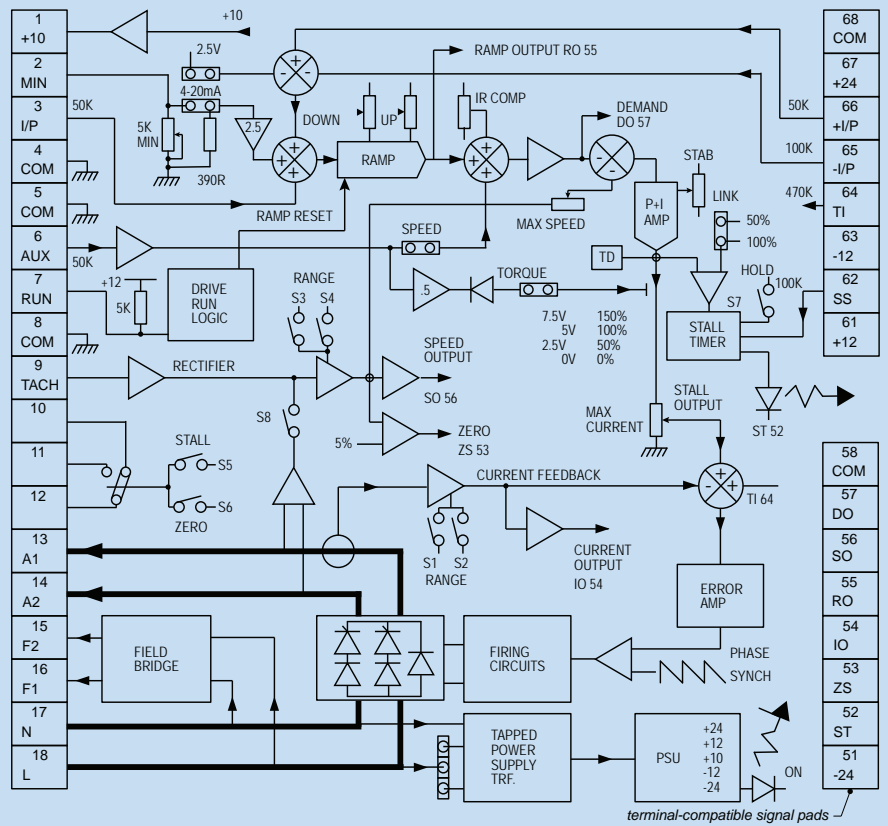

3200i variation

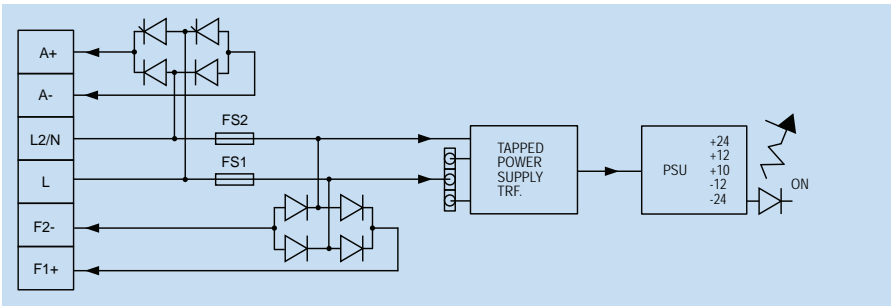

Figure 10 Block diagram

1	+10 V precision reference. 10 mA maximum. Short-circuit proof	
2	Minimum end of setpoint potentiometer or 4-20 mA current loop I/P	
3	Speed demand input, 0-+10 V for 0-100% speed	
4	Common - 4-20 mA return	
5	Common - connect to earth for protective Class 1	
6	Auxiliary input - on-board jumper selects direct speed or torque mode (0-10 V for 0-100% control)	
7	Connect to COMMON to run 60 ms ON / 20 ms OFF (WARNING: RUN is an electronic inhibit function. The field remains energised and all power terminals remain "live". RUN must not be relied upon during hazardous operations)	
8	Common - internally connected to T4, T5, T58, T68	
9	Tacho input 25-400 V full scale, + or - polarity	
10	Relay contact, normally-closed	Relay contact rating: 1 A, 240 Vac RATINGS ACCORDING TO CSA: voltage rating of relay terminals 10/11/12 must not exceed 30 Vac or 42.4 Vdc
11	Relay contact, normally-open	
12	Relay pole	
13	(A1+) armature output	
14	(A2-) armature output	
15	(F2-) field output	
16	(F1+) field output	
17	(N) AC supply input according to supply select jumper	
18	(L) AC supply input according to supply select jumper	



Top terminals

68	Drive common	
67	+24 V output, 25 mA maximum - do not short	
66	Auxiliary speed input, 0 to +10 V for 0-100% ramped speed	
65	Auxiliary inverting speed input, 0 to -10 V for 0-100% ramped speed	
64	Input to current loop, 0-5 V for 100% current	
63	-12 V output 10 mA maximum - do not short	
62	Stop/start input: close to -12 V to activate stall condition close to +12 V to release stall condition	
61	+12 V output, 10 mA maximum - do not short	
58	Drive common	
57	Speed demand output 0 to -10 V represents 0-100% demand (output impedance 1 kΩ)	
56	Speed output - typically 7.5 V full scale adjustment of maximum speed preset will alter the full scale reading from 4 V (anti-clockwise) to 9 V (clockwise)	
55	Setpoint ramp output, 0-10 V, impedance 1 kΩ	
54	Current output, 0-5 V for 0-100% of chosen range (S1, S2), 1 kΩ impedance	
53	Zero speed relay driver output, maximum 100 mA, switches to -24 V	
52	Stall relay driver output, maximum 100 mA, switches to -24 V	
51	-24 V relay supply, 25 mA - do not short	

Figure 11 1600i Terminal specifications

1	+10 V precision reference. 10 mA maximum. Short-circuit proof	
2	Minimum end of setpoint potentiometer or 4-20 mA current loop I/P	
3	Speed demand input, 0-+10 V for 0-100% speed	
4	Common - 4-20 mA return	
5	Common - connect to earth for protective Class 1	
6	Auxiliary input - on-board jumper selects direct speed or torque mode (0-10 V for 0-100% control)	
7	Connect to COMMON to run 60 ms ON / 20 ms OFF (WARNING: RUN is an electronic inhibit function. The field remains energised and all power terminals remain "live". RUN must not be relied upon during hazardous operations)	
8	Common - internally connected to T4, T5, T58, T68	
9	Tacho input 25-400 V full scale, + or - polarity	
10	Relay contact, normally-closed	Relay contact rating: 1 A, 240 Vac RATINGS ACCORDING TO CSA: voltage rating of relay terminals 10/11/12 must not exceed 30 Vac or 42.4 Vdc
11	Relay contact, normally-open	
12	Relay pole	
A1+	+armature output	
A2-	-armature output	
L2/N	AC supply input according to supply select jumper	
L	AC supply input according to supply select jumper	
F2-	-field output	
F1+	+field output	

Top terminals

68	Drive common	
67	+24 V output, 25 mA maximum - do not short	
66	Auxiliary speed input, 0 to +10 V for 0-100% ramped speed	
65	Auxiliary inverting speed input, 0 to -10 V for 0-100% ramped speed	
64	Input to current loop, 0-5 V for 100% current	
63	-12 V output 10 mA maximum - do not short	
62	Stop/start input: close to -12 V to activate stall condition close to +12 V to release stall condition	
61	+12 V output, 10 mA maximum - do not short	
58	Drive common	
57	Speed demand output 0 to -10 V represents 0-100% demand (output impedance 1 kΩ)	
56	Speed output - typically 7.5 V full scale adjustment of maximum speed preset will alter the full scale reading from 4 V (anti-clockwise) to 9 V (clockwise)	
55	Setpoint ramp output, 0-10 V, impedance 1 kΩ	
54	Current output, 0-5 V for 0-100% of chosen range (S1, S2), 1 kΩ impedance	
53	Zero speed relay driver output, maximum 100 mA, switches to -24 V	
52	Stall relay driver output, maximum 100 mA, switches to -24 V	
51	-24 V relay supply, 25 mA - do not short	

Figure 12 3200i Terminal specifications

3 Commissioning

3.1 Initial settings - without power

The suggested Commissioning strategy is to start in the safest possible mode of operation and progressively exercise each element of the system until full functionality has been achieved.

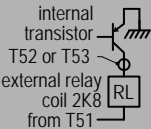
For this reason, all drive units are shipped to run using:

- the highest supply option
- a nominal speed
- ARMATURE VOLTAGE feedback mode - **we recommend that initial commissioning is carried out in Armature Voltage feedback mode**
- the lowest current range

1. To avoid damage, ensure the drive's supply selection jumper matches the incoming ac supply: 240 Vac or 110 Vac, (60 Vac or 30 Vac for LV60 models).

2. Ensure switch S8 is set to ON, selecting AVF.

Supply selection		
Drive model	HIGH position	LOW position
1600i	240 V	110 V
3200i	415 V	240 V
LV60	60 V	30 V



1600i



3200i

Refer also to "Figure 13 User adjustments" on page 13 for the following switch selections:

3. Use switches S1 and S2 to select a suitable current range. **IMPORTANT***: The switch settings vary between the 1600i and 3200i. Refer to the table below.

For example, if your motor current rating is 6 A, the switch settings for 1600i are SW1:ON and SW2:OFF, but for 3200i/8 they are SW1:OFF and SW2:ON.

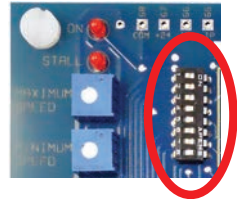

1600i : current ranges*			
S1	S2	Min.	Max.
OFF	OFF	0 A	4 A
ON	OFF	0 A	8 A
OFF	ON	0 A	12 A
ON	ON	0 A	16 A

3200i : current ranges*							
S1	S2	Min.	Max.	/8	/16	/32	/48
OFF	OFF	0 A		2 A	4 A	8 A	12 A
ON	OFF	0 A		4 A	8 A	16 A	24 A
OFF	ON	0 A		6 A	12 A	24 A	36 A
ON	ON	0 A		8 A	16 A	32 A	48 A

4. Use switches S3 and S4 to select a range suitable for the armature voltage at full speed. For example, if the armature voltage is 180 V, then set S3:OFF and S4:ON for 100 to 200 V voltage feedback.

5. For an initial start, adjust the following presets:

MIN SPEED	Fully anti-clockwise
UP RAMP	Fully anti-clockwise
DOWN RAMP	Fully anti-clockwise
STABILITY	Mid-way
IR COMP	Fully anti-clockwise
MAX CURRENT	Set MAX CURRENT from your motor rating plate. Rotating clockwise gives 0-100% of the drive current rating as set by switches S1/S2, e.g. if S1/S2 are set to limit the current to 8 A, 50% rotation will give a 4 A current limit.

6. If a tachogenerator is fitted, disconnect the tacho wire from terminal T9 and insulate.

3.2 Pre-operation motor check list

With no power applied, complete the following check list:

- Check for the correct insulation between all motor windings and earth (disconnect all drive cables before testing).
- Check inside the motor connection box for foreign objects, damaged terminals etc.
- Check that motor brushes are in good condition, correctly seated and free to move in brush boxes.
- Check for the correct action of brush springs.
- Check that motor vents are free of any obstruction or protective covers.

3.3 Operating the drive

1. Note the armature voltage rating given on the motor rating plate.
2. **Apply mains power to the unit.** The ON lamp will light.
3. Close the RUN contact.
4. Gradually increase the external setpoint to start the motor rotating. If the direction is wrong, TURN OFF THE POWER, WAIT FOR THE MOTOR TO STOP TURNING and swap over the cables connected to the A1+ and A2- terminals.
5. **MAX SPEED:** Increase the external setpoint further to ramp up to full speed. Fine adjust using the MAX SPEED preset to achieve the armature voltage stated on the motor rating plate.
6. Reduce the external setpoint to ramp the drive to zero. The motor will stop rotating.
7. **MIN SPEED:** Adjust MIN SPEED to provide a speed preset.
8. **RAMP UP/RAMP DOWN:** Run the motor up and down while adjusting the RAMP UP and RAMP DOWN potentiometers.
9. **STABILITY:** Adjust the STAB potentiometer to improve response. Clockwise rotation gives a faster response. (Excessive rotation in either direction may lead to instability, depending on load.)
10. **IR COMP:** Speed droop on heavy loads may occur where armature voltage feedback is used. Compensate for this by clockwise adjustment of the IR comp preset. Excessive rotation may lead to instability.

The drive is now commissioned for use in Armature Voltage feedback.



WARNING!

When power is applied to the drive, ALWAYS use an insulated tool when adjusting the presets.

★ 1600i 3200i

240 LV SUPPLY SELECT
 60 LV
 110 30

This jumper selects the appropriate supply tap on the control transformer. Refer to the specification for supply ranges.

AC power is applied when lit.

Drive quenches when lit if stall timer trips - the time depends upon the current demand:

STANDARD	WITH 50% THRESHOLD
150% 30 secs	150% 5 secs
125% 60 secs	100% 30 secs
115% 120 secs	75% 60 secs
100% no trip	50% no trip

- Rotate clockwise to increase speed. Change the range with S3 and S4.
- Rotate clockwise to increase minimum speed. Use to adjust 4-20 mA loop burden resistor between 0 and 390 Ω if 4-20 mA mode is selected.
- Rotate clockwise to increase drive acceleration from 1 to 30 seconds.
- Rotate clockwise to increase drive deceleration from 1 to 30 seconds - note that natural coast down is a limit.
- Rotate clockwise to increase response. Excessive rotation may cause instability. If rated motor voltage is much lower than AC supply then anticlockwise is preferred.
- Rotate clockwise to increase level of armature voltage droop compensation. Excessive rotation may cause instability. Always set fully anti-clockwise in Tacho mode.
- Rotate clockwise to increase current. S1 and S2 select the range.

STALL ON

S1 MAXIMUM CURRENT RANGE: Select between four maximum current ranges. 100% represents the maximum unit rating. Use the MAX CURRENT PRESET to adjust from 0% to the selected maximum percentage.

S2 MAXIMUM FEEDBACK RANGE: Select between four maximum feedback voltage ranges. Use the MAX SPEED PRESET to adjust within the range. The drive will control from 0 V to the selected maximum 0-10 V input.

S3 RELAY FUNCTION: Select the function of the internal relay: S5 - when ON, the relay remains energised until a stall condition occurs. S6 - when ON, the relay is energised for speeds 5% of full scale. S5 & S6 - when both ON, the relay de-energises when a stall condition occurs AND the motor speed has fallen below 5% of full scale.

S4 DRIVE STALL S6 ON ZERO SPEED S6 ON

S5 RELAY FUNCTION

S6 RELAY FUNCTION

S7 HOLD: When ON, the drive will power up in a stall condition. It may be reset by momentarily shorting pad T61 to pad T62.

S8 TACH/AVF: Select the speed feedback source: When ON, ARMATURE VOLTAGE is selected (default). When OFF, TACHO is selected.

TORQUE SPEED With a jumper in TORQUE position, terminal 6 is a torque input. With a jumper in SPEED position, terminal 6 is a direct speed input.

LINK FOR 4-20 MA Link both and terminal 2 becomes loop I/P compliance 5 V, and terminal 4 is return. Link just the lower pair for 0-20 mA.

50% STALL THRESHOLD Link for 50% STALL THRESHOLD.

1600i **3200i**

★ SUPPLY SELECT 1600i

The 3200i is 50 mm wider than the 1600i.

A pair of 2 A fuses protect the field and transformer. The supply select jumper is located at the top right edge (HIGH/LOW).

ANTI-CLOCKWISE MID-WAY CLOCKWISE



DANGER!
ELECTRIC SHOCK HAZARD

AC supply voltage legend, selector marked HIGH/LOW

Figure 13 User adjustments

4 Options

Consider the following changes to tune/improve the performance of the drive/system.

- **SPEED FEEDBACK SELECTION** If the system is to use **Tacho** feedback you can now adjust for the tachogenerator's output voltage, and hence the speed of the motor.

Run the drive in **Armature Voltage** feedback mode and check the polarity of the tacho using a voltmeter. The tacho feedback polarity must be negative with respect to COMMON, Terminal 8 for a Positive Speed Demand on Terminal 3.



WARNING! **PERSONAL INJURY HAZARD**

Terminals A1+, A2-, F1+, F2-, L2/N & L are at high potential.
Do not touch the terminals or any connected conductor.

NOTE: IR COMP must NOT be used with Tacho feedback - set the potentiometer fully anti-clockwise.

- a. With the power off, connect the tachogenerator's output voltage to Terminal 9. Set the **Tach/Avf** switch S8 to OFF (left).

Calculate the output voltage from the tachogenerator:

For example, if quoted as "100 V per 1000 revs/min" then
feedback voltage = (motor speed/1000) x 100 V

Alternatively, it can be estimated as follows:

1. Whilst still in Avf mode and running at 100% speed, measure the tacho volts on the wire intended for connection to Terminal 9 - **WARNING: possible high voltage.** Note this voltage, **stop the motor and turn off the supply.**
 2. Set the **Tach/Avf** switch S8 to OFF (left) to disconnect Avf and then reconnect the tacho wire to Terminal 9.
- b. Reset switches S3 and S4 to a suitable range for the measured/calculated Tacho voltage.
 - c. Run the drive using a low to middle speed setpoint.
 - d. Adjust the **Max spd** preset to achieve the required shaft speed at maximum speed setpoint.
- **TORQUE CONTROL MODE:** Switch S3 allows a Torque signal to be entered when ON via signal pad 64 (TI) which is on the top edge of the board.

5 Trouble shooting

The drive consists of two highly accurate feedback control loops.

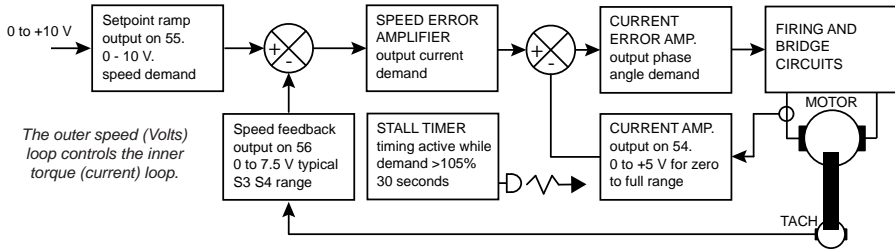

- 1 STALL problems, indicated by the STALL lamp coming on after running, are caused by the drive unit not able to give set speed.
- 2 Typical STALL reasons:
 - a. MAX CURRENT preset not correctly set, hence insufficient torque.
 - b. Motor not powerful enough for application. Speed calibration set beyond capability of supply.
 - c. Any factor which prevents motor from rotating at set speed, e.g. jammed load; low supply voltage.
- 3 Pot wired with T2 and T1 transposed. motor slows down instead of speeding up.
- 4 Pot wired with T2 and T3 transposed. Motor slows down for clockwise rotation. T1 may be shorted to T2.
- 5 Pot wired with T1 and T3 transposed. Motor slows down for anti-clockwise rotation. T1 becomes shorted to T2.
- 6 Loose or intermittent tacho coupling causes instability or overspeeding. make sure coupling is secure and non-elastic.
- 7 Incorrect feedback scaling causes overspeeding. Calculate the desired maximum tacho Volts - adjust S3, S4.
- 8 Tacho failure. Until a replacement is obtained, change to ARMATURE VOLTAGE feedback, S8. Rescale with S3, S4.
- 9 Armature resistance should normally be a few Ohms. The armature time constant must be greater than 10 milliseconds.
- 10 Shorted turn on motor armature can cause power device failure. Check resistance through 360° rotation.
- 11 Brushes should be in good condition, correctly seated, and free to move in brush boxes.
- 12 Field resistance should normally be a few hundred Ohms. The field must be isolated from earth and the armature.
- 13 Do not open circuit field. Do not open circuit armature unless RUN is opened first.
- 14 The AC supply must lie within the limits specified on page 16. Ensure the selection jumper is correct.

NOTE: The 3200i has internal field fuses, FS1 and FS2, that protect the field output and PSU transformer. Failure of these fuses will disable the drive.

6 Specifications

Function	Specification	Comments
CONTROL ACTION	DUAL LOOP PROPORTIONAL + INTEGRAL	
FEEDBACK METHOD	ARMATURE VOLTS TACHOMETER	SWITCH SELECTABLE
0-100% REGULATION	2% TYPICAL 0.1% TYPICAL	BEWARE MOTOR HEAT AT LOW SPEED
MAX TORQUE SPEED RANGE	20 : 1 100 : 1	
OVERLOAD	150% CONTINUOUS CURRENT FOR 30 SECONDS	
Customer Presets		
MAX SPEED	25 - 400 V FULL SCALE FEEDBACK	SWITCH SELECTABLE
MIN SPEED	0-30% OF MAX SPEED	NON-INTERACTIVE
UP/DOWN RAMPS	INDEPENDENTLY ADJUSTABLE 1-30 SECONDS	LINEAR RAMPS
STABILITY	VARIABLES SPEED LOOP GAIN	
IR COMPENSATION	0-30% OF ARMATURE VOLTAGE	DO NOT USE WITH TACHO
MAX CURRENT	LINEAR SETTING FROM 0-100%, 4 SWITCHED RANGES	150% OVERLOAD
Switch Selectable		
CURRENT RANGE	FOUR RANGES OF ARMATURE CURRENT	S1, S2
SPEED RANGE	FOUR RANGES OF FEEDBACK VOLTAGE	S3, S4
RELAY FUNCTION	DRIVE STALL OR ZERO SPEED RELAY	S5, S6
POWER UP HOLD	POWER UP INSTALL OR RUN MODE	S7
TACHO/AVF	SELECT TACHO OR ARMATURE VOLTAGE FEEDBACK	S8
Jumper Functions		
TORQUE MODE	0-10 V INPUT FOR 0-100% CURRENT WITH AUTOMATIC OVERSPEED PROTECTION	JUMPER SELECTABLE
SUPPLY SELECT	DUAL SUPPLY VOLTAGE SELECTOR	JUMPER SELECTABLE
Link Functions		
4-20 mA OR 0-20 mA LOOP	ALLOWS CURRENT LOOP SIGNAL INPUT FOR SPEED	5 V COMPLIANCE
50% STALL LEVEL	ALLOWS LARGE PEAK CURRENTS	150% PEAK
SUPPLY RANGES		
	LV30 LV60 110 240 415	
45 Hz to 65 Hz	MAX 36 V 72 V 130 V 264 V 440 V	OVER FULL TEMP RANGE WITH OUTPUTS LOADED
AUTO RANGING	MIN 27 V 54 V 100 V 200 V 360 V	
AC POWER RESET	MINIMUM OFF TIME BEFORE RE-SUPPLY	500 ms
RUN LINE	60 ms ON, 20 ms OFF. ALWAYS USE A RUN CONTACT TO ENABLE THE DRIVE AFTER THE APPLICATION OF AC	
SIGNAL OUTPUTS	SPEED, CURRENT, RAMP, DEMAND	ALL BUFFERED
SIGNAL INPUTS	3 SPEED INPUTS +/- RAMPED, DIRECT, ALL SUMMING	PROTECTED
RELAY OUTPUTS	STALL OR ZERO SPEED RELAY	VOLT-FREE CHANGEOVER
RELAY DRIVERS	STALL, ZERO SPEED OPEN COLLECTOR PNP	FOR -24 Vdc 100 mA MAX
RAIL OUTPUTS	-24 V UNREGULATED 10 mA +12 V, +10 V, -12 V REGULATED 10 mA	+/- 20% 0.01%/DEG C 5%
FIELD OUTPUT	0.9 (0.45) x AC SUPPLY. 1600i 1 A, 3200i 2 A.	FULL (0.9) OR HALF WAVE (0.45)
IP RATING	IP00	
ALTITUDE	3000 METRES MAX FOR FULL RATING	DE-RATE 1%/100m
HUMIDITY	85% R.H AT 40°C, NON-CONDENSING	
FORM FACTOR	TYPICAL 1.5 AT MAX OUTPUT	
TEMPERATURE	STORAGE AND OPERATING -10 TO + 50°C	
ARMATURE TIME CONSTANT	MINIMUM 10 ms. USE EXTRA ARMATURE CHOKE TO INCREASE	T= INDUCTANCE/RESISTANCE
MAX I ² t FUSING (Amps ² Seconds)	1600i = 365 3200i/8 = 365, 3200i/16 = 555, 3200i/32 = 940, 3200i/48 = 4750	SEMICONDUCTOR FUSES Refer to page 2

Disposal

This product contains materials that are consignable waste under the Hazardous Waste Regulations 2005. Metal and plastic materials can be recycled, however, disposal of the printed circuit board requires compliance with all valid environmental control laws.



Products that must be recycled in accordance with the WEEE Regulations are marked with the symbol opposite. Contact us when recycling the product.



©2021, Sprint Electric. All rights reserved.

We accept no liability whatsoever for the installation, fitness for purpose or application of this product.

It is the user's responsibility to ensure the unit is correctly used and installed.

This leaflet is protected by copyright. No part of it may be stored or reproduced in any form without written permission from Sprint Electric.

The information in this publication was correct at the time of going to print.

We reserve the right to modify or improve the product without notification.

The contents of this manual shall not become part of or modify any prior existing agreement, commitment, or relationship. The sales contract contains the entire obligation of Sprint Electric. The warranty contained in the contract between the parties is the sole warranty of Sprint Electric. Any statements contained herein do not create new warranties or modify the existing warranty.

We will be under no liability for any defect arising from fair wear and tear, negligence, wilful damage, misuse, abnormal working conditions, failure to follow the manufacturer's instructions, unauthorised alteration or repair of hardware, unauthorised or accidental alteration of software or configuration, lost profits, commercial loss, economic loss, or loss arising from personal injury. We may, at our discretion, raise a charge for any faults repaired that fall outside the warranty cover.